

# **PAMS Technical Documentation**

## **NHM-7 Series Transceivers**

# **System Module & UI**

## CONTENTS

Transceiver NHM-7 .....	6
Introduction .....	6
Electrical Modules .....	6
Operation Modes .....	7
Interconnection Diagram .....	7
System Module .....	8
Baseband Module .....	8
Block Diagram .....	8
Technical Summary .....	9
DC Characteristics .....	10
Regulators and Supply Voltage Ranges .....	10
External and Internal Signals and Connections .....	11
Internal Signals and Connections .....	11
FM Radio Interface .....	11
Internal microphone .....	12
Internal speaker .....	12
AC and DC Characteristics of RF-BB voltage supplies .....	13
AC and DC Characteristics of RF-BB digital signals ..	14
AC and DC Characteristics of RF-BB analogue signals ..	15
External Signals and Connections .....	16
UI (board-to-board) connector .....	16
LCD connector .....	17
DC connector .....	18
Headset connector .....	18
SIM connector .....	19
Functional Description .....	20
Modes of Operation .....	20
Supply Voltage Regulation .....	21
Battery .....	22
Power Up and Reset .....	22
A/D Channels .....	23
FM Radio .....	24
IR Module .....	25
Backup Battery .....	25
SIM Interface .....	25
Buzzer .....	26
Internal Microphone .....	26
UPP .....	27
Memory Block .....	27
RF Module .....	29
RF Frequency Plan .....	29
DC characteristics .....	30
Regulators .....	30
Power Distribution Diagram .....	31

RF characteristics .....	32
Transmitter characteristics .....	32
Receiver characteristics .....	32
RF Block Diagram .....	33
Frequency synthesizers .....	34
Receiver .....	35
Transmitter .....	36
AFC function .....	36
DC-compensation .....	37
UI Board .....	38
LCD & Keypad Illumination .....	38
Internal Speaker .....	39

Schematic Diagrams (at the back of the binder): LA5 layout 15 and LK5 layout 11 (covers layout version 10)

RF & BB (Version 0.0 Edit 61) for layout version 15 .....	A-1
RF (Version 1.0 Edit 167) for layout version 15 .....	A-2
BB Connections (Version 0.0 Edit 96) for layout version 15 ..	A-3
System Connector (Version 1.3 Edit 156) for layout version 15	A-4
Audio Interface (Version 1.3 Edit 15) for layout version 15 ...	A-5
UEM of BB (Version 2.0 Edit 164) for layout version 15 .....	A-6
Light Filtering (Version 2.0 Edit 34) for layout version 15 ....	A-7
Display and Keyboard Interface (Version 1.3 Edit 201) for layout version 15	A-8
Infrared Module (Version 2.0 Edit 37) for layout version 15 ..	A-9
FM Radio (Version 1.3 Edit 104) for layout version 15 .....	A-10
SIM Reader (Version 4.0.1 Edit 49) for layout version 15 ....	A-11
UPP and decoupling capacitors (Version 2.0 Edit 89) for layout version 15	A-12
AMD (Version 2.0 Edit 31) for layout version 15 .....	A-13
Layout Diagram of LA5 – Top (Version 15) .....	A-14
Layout Diagram of LA5 – Bottom (Version 15) .....	A-14
Testpoints of LA5 – Top (Version 15) .....	A-15
Testpoints of LA5 – Bottom (Version 15) .....	A-15
UI Board – LK5 for version 11 .....	A-16
Layout Diagram – LK5 for version 11 .....	A-17

Schematic Diagrams (at the back of the binder): LA5 layout 17 and LK5 layout 11 (covers layout version 10)

RF & BB (Version 0.0 Edit 65) for layout version 17 .....	B-1
RF (Version 1.0 Edit 180) for layout version 17 .....	B-2
BB Connections (Version 0.0 Edit 113) for layout version 17 .	B-3
System Connector (Version 1.3 Edit 162) for layout version 17	B-4
Audio Interface (Version 1.3 Edit 80) for layout version 17 ...	B-5
UEM of BB (Version 2.0 Edit 168) for layout version 17 .....	B-6
Light Filtering (Version 2.0 Edit 34) for layout version 17 ....	B-7
Display and Keyboard Interface (Version 1.3 Edit 210) for layout version 17	B-8
Infrared Module (Version 2.0 Edit 38) for layout version 17 ..	B-9
FM Radio (Version 1.3 Edit 110) for layout version 17 .....	B-10
SIM Reader (Version 1.3 Edit 48) for layout version 17 .....	B-11
UPP and decoupling capacitors (Version 2.0 Edit 91) for layout version 17	B-12
GSM RF – BB Interface (Version 1.3 Edit 35) for layout version 17	B-13
Flash Memory (Version 2.0 Edit 32) for layout version 17 ....	B-14
Layout Diagram of LA5 – Top (Version 17) .....	B-15
Layout Diagram of LA5 – Bottom (Version 17) .....	B-15
Testpoints of LA5 – Top (Version xx) .....	B-16
Testpoints of LA5 – Bottom (Version 17) .....	B-16
UI Board – LK5 for version 11 .....	B-17
Layout Diagram – LK5 for version 11 .....	B-18

This page intentionally left blank.

## Transceiver NHM-7

### Introduction

The NHM-7 is a dual band radio transceiver unit for the E-GSM900 and GSM1800 networks. GSM power class is 4 and GSM1800 power class is 1. It is a true 3 V transceiver, with an internal antenna and vibra.

The NHM-7 phone includes integrated FM radio. Radio is used as a normal mono receiver. FM radio is highly integrated. Only few external components are needed. Headset is used as an antenna for radio.

The transceiver has a full graphic display and the user interface is based on a Jack style UI with two soft keys.

An internal antenna is used, there is no connection to an external antenna.

The transceiver has a low leakage tolerant earpiece and an omnidirectional microphone, providing an excellent audio quality. The transceiver supports a full rate, an enhanced full rate and a half rate speech decoding.

An integrated IR link provides a connection between two NHM-7 transceivers or a transceiver and a PC (internal data), or a transceiver and a printer.

The small SIM (Subscriber Identity Module) card is located under the battery. SIM interface supports both 1.8V and 3V SIM cards.

### Electrical Modules

The radio module consists of Radio Frequency (RF) and baseband (BB). User Interface (UI) contains display, keyboard, IR link, vibra, HF/HS connector and audio parts. UI is divided into radio PWB LA5 and UI PWB LK5. FM radio is located on the main PWB.

The electrical part of the keyboard is located in separate UI PWB named LK5. LK5 is connected to radio PWB through spring connectors.

The System blocks provide the MCU, DSP, external memory interface and digital control functions in UPP ASIC (Universal Phone Processor). Power supply circuitry, charging, audio processing and RF control hardware are in UEM ASIC (Universal Energy Management).

The purpose of the RF block is to receive and demodulate the radio frequency signal from the base station and to transmit a modulated RF signal to the base station.

## Operation Modes

The transceiver has six different operation modes:

- power off mode
- active mode
- local mode
- idle mode
- charge mode
- test mode

In the power off mode circuits are powered down and only sleep clock is running.

In the idle mode only the circuits needed for power up are supplied.

In the active mode all the circuits are supplied with power although some parts might be in the idle state part of the time.

The charge mode is effective in parallel with all previous modes. The charge mode itself consists of two different states, i.e. the fast charge and the maintenance mode.

The local and test modes are used for alignment and testing.

## Interconnection Diagram

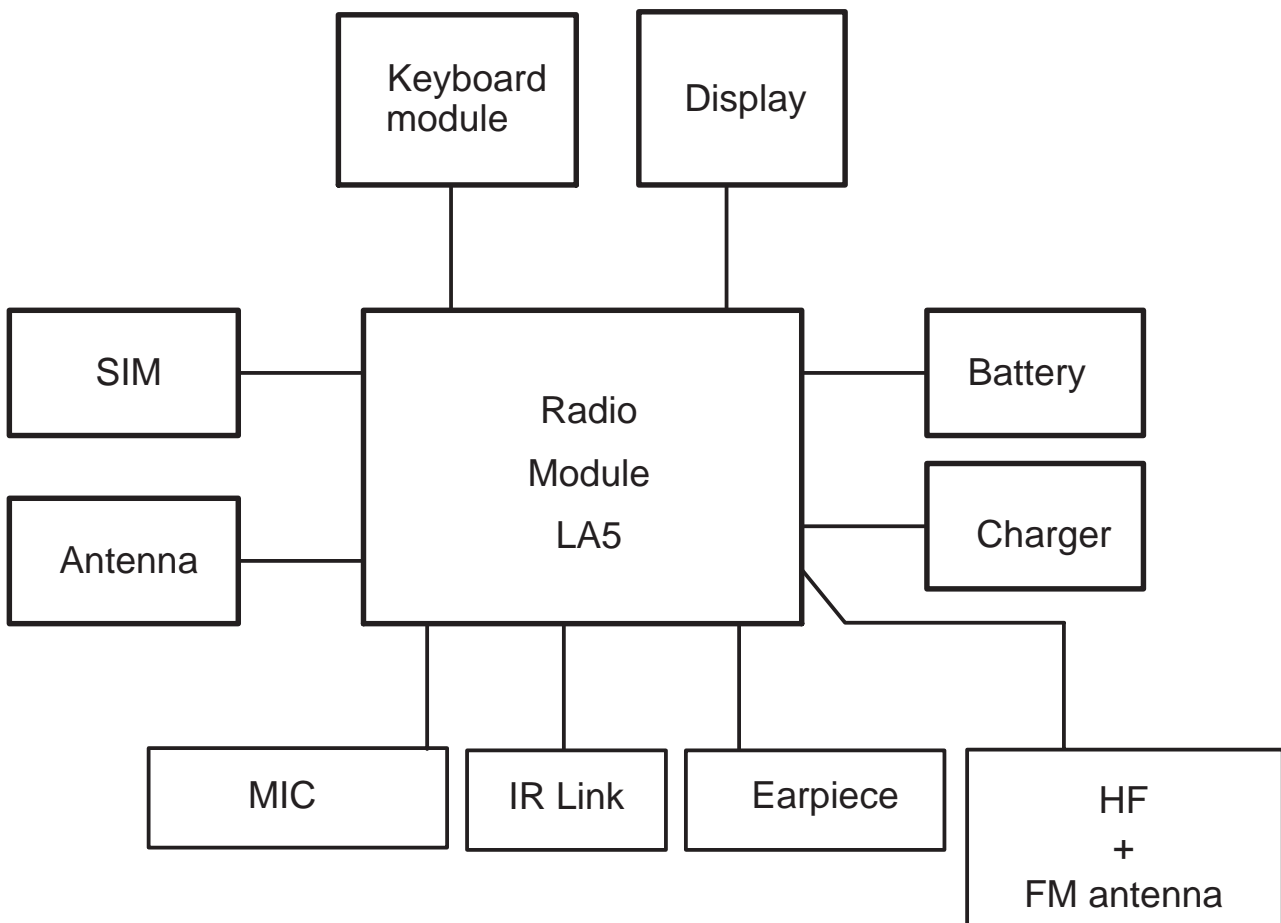

## System Module LA5

### Baseband Module

The baseband architecture supports a power saving function called "sleep mode". This sleep mode shuts off the VCTCXO, which is used as system clock source for both RF and baseband. During the sleep mode the system runs from a 32 kHz crystal. The phone is waken up by a timer running from this 32 kHz clock supply. The sleep time is determined by network parameters. Sleep mode is entered when both the MCU and the DSP are in standby mode and the normal VCTCXO clock is switched off.

NHM-7 supports both three and two wire type of Nokia chargers. Three wire chargers are treated like two wire ones. There is not separate PWM output for controlling charger but it is connected to GND inside the bottom connector. Charging is controlled by UEM ASIC (Universal Energy Management) and EM SW running in the UPP (Universal Phone Processor).

BLB-2 Li-ion battery is used as main power source for the phone.

### Block Diagram

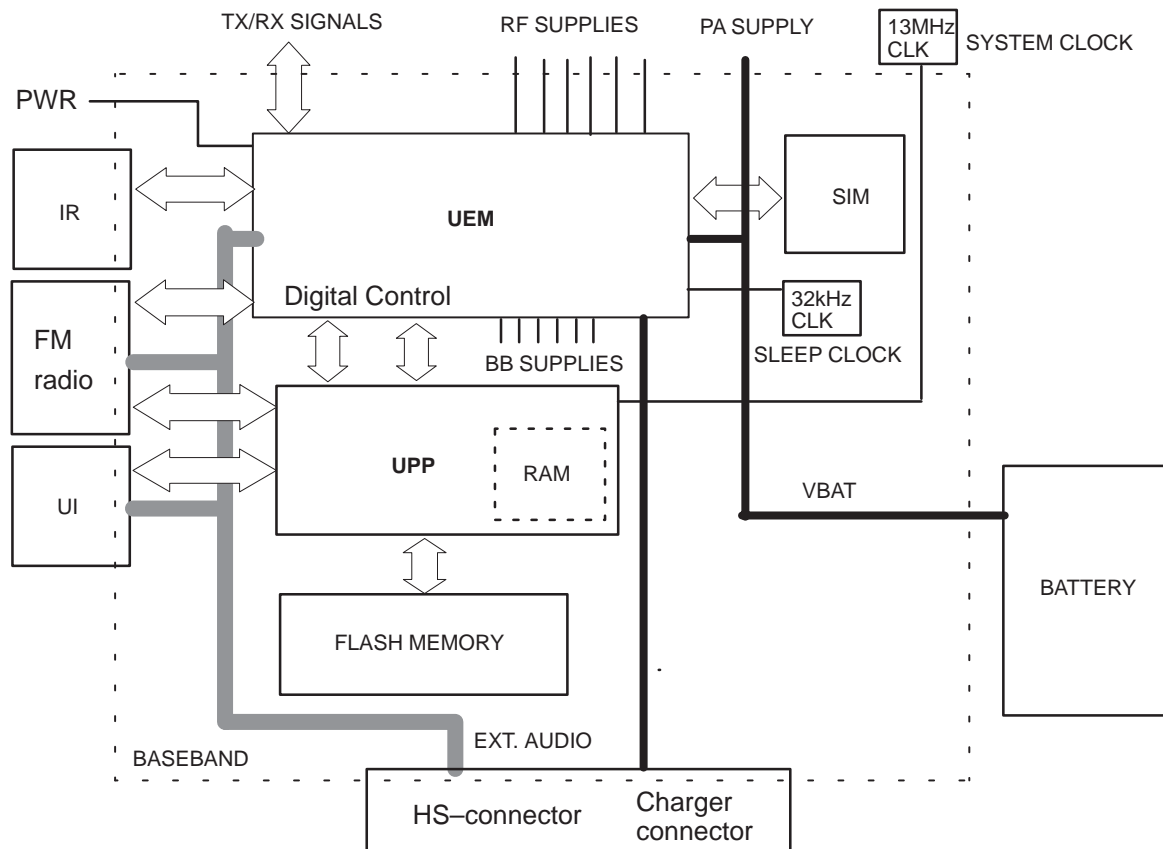

UPP ASIC (Universal Phone Processor) provides the MCU, DSP, external memory interface and digital control functions. UEM ASIC (Universal Energy Management) contains power supply circuitry, charging, audio processing and RF control hardware.



## Technical Summary

Baseband is running from power rails 2.8V analog voltage and 1.8V I/O voltage. UPP core voltage Vcore can be lowered down to 1.0V, 1.3V and 1.5V. UEM includes 6 linear LDO (low drop-out) regulators for baseband and 7 regulators for RF. It also includes 4 current sources for biasing purposes and internal usage. UEM also includes SIM interface which has supports both 1.8V and 3V SIM cards.

**Note:** 5V SIM cards are no longer supported by NHM-7 baseband.

A real time clock function is integrated into the UEM which utilizes the same 32kHz clock supply as the sleep clock. A backup power supply is provided for the RTC which keeps the real time clock running when the main battery is removed. The backup power supply is a rechargeable surface mounted capacitor. The backup time with the capacitor is 30 minutes minimum.

The analog interface between the baseband and the RF section is handled by a UEM ASIC. UEM provides A/D and D/A conversion of the in-phase and quadrature receive and transmit signal paths and also A/D and D/A conversions of received and transmitted audio signals to and from the user interface. The UEM supplies the analog TXC and AFC signals to RF section according to the UPP DSP digital control. Data transmission between the UEM and the UPP is implemented using two serial busses, DBUS for DSP and CBUS for MCU. RF ASIC, Hagar, is controlled through UPP RFBUS serial interface. There is also separate signals for PDM coded audio. Digital speech processing is handled by the DSP inside UPP ASIC. UEM is a dual voltage circuit, the digital parts are running from the baseband supply 1.8V and the analog parts are running from the analog supply 2.78V also VBAT is directly used by some blocks.

The baseband supports both internal and external microphone inputs and speaker outputs. UEM also includes third microphone input which is used in NHM-7 for FM radio. Input and output signal source selection and gain control is done by the UEM according to control messages from the UPP. Keypad tones, DTMF, and other audio tones are generated and encoded by the UPP and transmitted to the UEM for decoding. A buzzer and external vibra alert control signals are generated by the UEM with separate PWM outputs.

NHM-7 has two external serial control interfaces: FBUS and MBUS. These busses can be accessed only through production test pattern.

EMC shielding for baseband is implemented using a metallized plastic frame and UI PWB ground plane. On the other side the engine is shielded with PWB grounding. Heat generated by the circuitry will be conducted out via the PWB ground planes.

NHM-7 radio module is implemented to 8 layer PWB. UI module is divided between main PWB LA5 and separate UI PWB LK5.

## DC Characteristics

### Regulators and Supply Voltage Ranges

#### Battery Voltage Range

Signal	Min	Nom	Max	Note
VBAT	3.1V	3.6V	4.2V (charging high limit voltage)	3.1V SW cut off

#### BB Regulators

Signal	Min	Nom	Max	Note
VANA	2.70V	2.78V	2.86V	$I_{max} = 80mA$
VFLASH1	2.70V	2.78V	2.86V	$I_{max} = 70mA$ $I_{Sleep} = 1.5mA$
VFLASH2	2.70V	2.78V	2.86V	$I_{max} = 40mA$
VSIM	1.745V 2.91V	1.8V 3.0V	1.855V 3.09V	$I_{max} = 25mA$ $I_{Sleep} = 0.5mA$
VIO	1.72V	1.8V	1.88V	$I_{max} = 150mA$ $I_{Sleep} = 0.5mA$
VCORE	1.0V 1.235V 1.425V 1.710V	1.053V 1.3V 1.5V 1.8V	1.106V 1.365V 1.575V 1.890V	$I_{max} = 200mA$ $I_{Sleep} = 0.2mA$ Default value = 1.5V

#### RF Regulators

Signal	Min	Nom	Max	Note
VR1A	4.6V	4.75V	4.9V	$I_{max} = 10mA$
VR2	2.70V 3.20V	2.78V 3.3V	2.86V 3.40V	$I_{max} = 100mA$
VR3	2.70V	2.78V	2.86V	$I_{max} = 20mA$
VR4	2.70V	2.78V	2.86V	$I_{max} = 50mA$ $I_{Sleep} = 0.1mA$
VR5	2.70V	2.78V	2.86V	$I_{max} = 50mA$ $I_{Sleep} = 0.1mA$
VR6	2.70V	2.78V	2.86V	$I_{max} = 50mA$ $I_{Sleep} = 0.1mA$
VR7	2.70V	2.78V	2.86V	$I_{max} = 45mA$

## External and Internal Signals and Connections

This section describes the external and internal electrical connection and interface levels on the baseband. The electrical interface specifications are collected into tables that covers a connector or a defined interface.

### Internal Signals and Connections

#### FM Radio Interface

BB Signal	FM Radio Signal	Min	Nom	Max	Condition	Note
VFLASH2	Vcc1	2.7V	2.78V	2.86V		max. Icc1 19mA
	Vcc2	2.7V	2.78V	2.86V		max. Icc2 800uA
	VDD	2.7V	2.78V	2.86V		max. IDD 3mA
GenIO(3)	FMClk	1.4V 0	1.8V	1.88V 0.4V	High Low	Reference clock for FM radio module
			76471 Hz		Frequency	In GSM
		30ppm			Stability	
				2 $\mu$ s	$t_{rise}$	rise / fall time
GenIO(8)	FMWrEn	1.4V 0V	1.8V	1.88V 0.4V	High Low	
		20 $\mu$ s			$t_{wd}$	<i>FMWrEn</i> high before rising edge of <i>FMCtrlClk</i> (write opera- tion)
GenIO(11)	FMCtrlClk	1.4V 0	1.8V	1.88V 0.4V	High Low	max. 300kHz
				1 $\mu$ s	$t_r / t_f$	rise / fall time
		50 ms			$t_{start}$	<i>FMCtrlClk</i> delay after switching on the VFLASH2 (oscillator run- ning)

BB Signal	FM Radio Signal	Min	Nom	Max	Condition	Note
GenIO(12)	FMCtrlDa	1.4V 0	1.8V	1.88V 0.4V	High Low	Bidirectional
				14us	t <sub>da</sub>	shift register available after "search ready"
		10 μs			t <sub>shift</sub>	data available after FMCtrlClk rising edge (read operation)
		1.5 μs			t <sub>hold</sub>	FMCtrlDa stable after FMCtrlClk rising edge (write operation)
GenIO(27)	FMTuneX	1.4V 0	1.8V	1.88V 0.4V	High Low	from FM module to UPP (FMCtrlClk = '1')
MIC3P	FMAudio	228mV <sub>pp</sub>	326mV <sub>pp</sub>	460mV <sub>pp</sub>		
		50dB			S/N	
				2%	Harmonic distortion	

### Internal microphone

Signal	Min	Nom	Max	Condition	Note
MICP			200mV <sub>pp</sub>	AC	2.2kΩ to MIC1B
	2.0 V	2.1 V	2.25 V	DC	
MICN	2.0V	2.1V	2.25V	DC	

### Internal speaker

Signal	Min	Nom	Max	Condition	Note
EARP	0.75V	0.8V	2.0 V <sub>pp</sub>	AC	Differential output (V <sub>diff</sub> = 4.0 V <sub>pp</sub> )
			0.85V	DC	
EARN	0.75V	0.8V	2.0 V <sub>pp</sub>	AC	
			0.85V	DC	

**AC and DC Characteristics of RF-BB voltage supplies**

Signal name	From	To	Parameter	Min	Typ	Max	Unit	Function
VBAT	Battery	PA & UEM	Voltage	2.95	3.6	4.2	V	Battery supply. Cut-off level of DCT4 regulators is 3.04V. Losses in pcb tracks and ferrites are taken account to minimum battery voltage level.
			Current			2000	mA	
			Current drawn by PA when "off"		0.8	2	uA	
VR1A	UEM	VCP	Voltage	4.6	4.75	4.9	V	Supply for varactor for UHF VCO tuning.
			Current		2	10	mA	
			Noise density			240	nVrms/sqrt(Hz)	
VR2	UEM	VRF_TX	Voltage	2.70	2.78	2.86	V	Supply for part of transmit strip. Supply for TX I/Q-modulators.
			Current		65	100	mA	
			Noise density f=100Hz f>300Hz			120	nVrms/sqrt(Hz)	
VR3	UEM	VCTCXO	Voltage	2.70	2.78	2.86	V	Supply for VCTCXO
			Current		1	20	mA	
			Noise density			240	nVrms/sqrt(Hz)	
VR4	UEM	VRF_RX	Voltage	2.70	2.78	2.86	V	Supply for Hagar RX; preamp., mixer, DTOS Noise density decades 20dB/dec from 6Hz to 600Hz. From f >600Hz maximum noise density 55nV <sub>RMS</sub> /√Hz.
			Current			50	mA	
			Noise density f = 6 Hz f = 60 Hz f ≥ 600Hz			5500 550 55	nVrms/sqrt(Hz)	
VR5	UEM	VDIG, VPRE, VLO	Voltage	2.70	2.78	2.86	V	Supply for Hagar PLL; dividers, LO-buffers, prescaler,
			Current			50	mA	
			Noise density BW=100Hz... 100kHz			240	nVrms/sqrt(Hz)	
VR6	UEM	VBB	Voltage	2.70	2.78	2.86	V	Supply for Hagar BB and LNA
			Current			50	mA	
			Noise density BW=100Hz... 100kHz			240	nVrms/sqrt(Hz)	

Signal name	From	To	Parameter	Min	Typ	Max	Unit	Function
VR7	UEM	UHF VCO	Voltage	2.70	2.78	2.86	V	Supply for UHF VCO
			Current			30	mA	
			Noise density 100Hz<f<2kHz 2kHz<f<10kHz 10kHz<f<30kHz 30kHz<f<90kHz 90kHz<f<3MHz			70 55 35 30 30	nVrms/ sqrt(Hz)	
VrefRF01	UEM	VREF_RX	Voltage	1.334	1.35	1.366	V	Voltage Reference for RF-IC.  <b>Note:</b> Below 600Hz noise density is allowed to increase 20 dB/oct
			Current			100	uA	
			Temp Coef	-65		+65	uV/C	
			Noise density BW=600Hz... 100kHz <b>Note</b>			60	nVrms/ sqrt(Hz)	
VrefRF02	UEM	VB_EXT	Voltage	1.323	1.35	1.377	V	Supply for RF-BB digital interface and some digital parts of RF.
			Current			100	uA	
			Temp Coef	-65		+65	uV/C	
			Noise density BW=100Hz... 100kHz			350	nVrms/ sqrt(Hz)	

### AC and DC Characteristics of RF-BB digital signals

Signal name	From	To	Parameter	Input Characteristics				Function
				Min	Typ	Max	Unit	
TXP (RFGenOut3)	UPP	PA & RF-IC	"1"	1.38		1.88	V	Transmitter power amplifier enable / DC N2 timing??
			"0"	0		0.4	V	
			Load Resistance	10		220	kohm	
			Load Capacitance			20	pF	
			Timing Accuracy			1/4	symbol	

Signal name	From	To	Parameter	Min	Typ	Max	Unit	Function
RFBusEna1X	UPP	RF-IC	"1"	1.38		1.88	V	RFbus enable
			"0"	0		0.4	V	
			Current			50	uA	
			Load resistance	10		220	kohm	
			Load capacitance			20	pF	
RFBusData	UPP	RF-IC	"1"	1.38		1.88	V	RFbus data ; read/write
			"0"	0		0.4	V	
			Load resistance	10		220	kohm	
			Load capacitance			20	pF	
			Data frequency			10	MHz	
RFBusClk	UPP	RF-IC	"1"	1.38		1.88	V	RFbus clock
			"0"	0		0.4	V	
			Load resistance	10		220	kohm	
			Load capacitance			20	pF	
			Data frequency			10	MHz	
RESET (GENIO6)	UPP	RF-IC	"1"	1.38		1.85	V	Reset to Hag ar
			"0"	0		0.4	V	
			Load capacitance			20	pF	
			Load resistance	10		220	kohm	
			Timing accuracy			1/4	symbol	

**AC and DC Characteristics of RF-BB analogue signals**

Signal name	From	To	Parameter	Min	Typ	Max	Unit	Function
VCTCXO	VCTCXO	UPP	Signal amplitude	0.2	0.8	2.0	Vpp	High stability clock signal for the logic circuits, AC coupled. Distorted sine wave eg. sawtooth.
			Input Impedance	10			kohm	
			Input Capacitance			10	pF	
			Harmonic Content			-8	dBc	
			Clear signal window (no glitch)	200			mVpp	
			Duty Cycle	40		60	%	
VCTCXOGnd	VCTXO	UPP	DC Level		0		V	Ground for reference clock
RXI/RXQ	RF-IC	UEM	Differential voltage swing (static)	1.35	1.4	1.45	Vpp	RX baseband signal.
			DC level	1.3	1.35	1.4	V	
			I/Q amplitude mismatch			0.2	dB	
			I/Q phase mismatch	-5		5	deg	

Signal name	From	To	Parameter	Min	Typ	Max	Unit	Function	
TXIP / TXIN	UEM	RF-IC	Differential voltage swing (static)	2.23		2.48	Vpp	Programmable voltage swing. Programmable common mode voltage. Between TXIP-TXIN	
			DC level	1.17	1.20	1.23	V		
			Source Impedance			200	ohm		
TXQP / TXQN	UEM	RF-IC	Same spec as for TXIP / TXIN						Differential quadrature phase TX baseband signal for the RF modulator
AFC	UEM	VCTCXO	Voltage Min Max	0.0 2.4		0.1 2.6	V	Automatic frequency control signal for VCTCXO	
			Resolution	11			bits		
			Load resistance and capacitance	1		100	kohm nF		
			Step settling time			0.2	ms		
Aux_DAC (TxC)	UEM	RF	Voltage Min Max	2.4		0.1	V	Transmitter power control  NOTE; Assumed power control opamp G=1	
			Source Impedance			200	ohm		
			Resolution	10			bits		
			Noise density BW=100Hz... 100kHz			800	nVrms/ sqrt(Hz)		
			Temp Coef	-65		+65	uV/C		
RFTemp	RF	UEM	Voltage at -20°C		1,57		V	Temperature sensor of RF.	
			Voltage at +25°C		1,7				
			Voltage at +60°C		1,79				
Vbase	RF	UEM	Voltage			2.7	V	Detected voltage from PA power level sensing unit	

## External Signals and Connections

### UI (board-to-board) connector

Pin	Signal	Min	Nom	Max	Condition	Note
1	SLOWAD(2)	1.5V 0.1V		2.7V 1.0V	Flip closed Flip open	used for flip identification
2	VBAT	3.0V	3.6V	4.2V		Battery voltage for leds
3	ROW(4)	0.7xVIO 0		1.8V 0.3xVIO	High Low	Keyboard matrix row 4



Pin	Signal	Min	Nom	Max	Condition	Note
4	ROW(3)	0.7xVIO 0		VIO 0.3xVIO	High Low	Keyboard ma- trix row 3
5	COL(2)	0.7xVIO 0		VIO 0.3xVIO	High Low	Keyboard ma- trix column 2
6	ROW(2)	0.7xVIO 0		VIO 0.3xVIO	High Low	Keyboard ma- trix row 2
7	COL(1)	0.7xVIO 0		VIO 0.3xVIO	High Low	Keyboard ma- trix column 1
8	ROW(0)	0.7xVIO 0		VIO 0.3xVIO	High Low	Keyboard ma- trix row 0
9	KLIGHT			VBAT 0.3xVBAT	LED off LED on	two colour led control
10	ROW(1)	0.7xVIO 0		VIO 0.3xVIO	High Low	Keyboard ma- trix row 1
11	COL(3)	0.7xVIO 0		VIO 0.3xVIO	High Low	Keyboard ma- trix column 3
12	COL(4)	0.7xVIO 0		VIO 0.3xVIO	High Low	Keyboard ma- trix column 4
13	GND		0V			
14	GND		0V			
15	GND		0V			
16	GND		0V			

### LCD connector

Pin	Signal	Min	Nom	Max	Condition	Note
1	XRES	0.8*VIO 0		VIO 0.22*VIO	Logic '1' Logic '0'	Reset Active low
		100ns			t <sub>rw</sub>	Reset active
2	XCS	0.8*VIO 0		VIO 0.22*VIO	Logic '1' Logic '0'	Chip select Active low
		130ns			t <sub>css</sub>	XCS low before SCLK rising edge
		130ns			t <sub>csh</sub>	XCS low after SCLK rising edge
		300ns			t <sub>csw</sub>	XCS high pulse width
3	GND		0V			
4	SDA	0.8*VIO 0		VIO 0.22*VIO	Logic '1' Logic '0'	Serial data (driver input)
		0.7*VIO 0		VIO 0.3*VIO	Logic '1' Logic '0'	Serial data (driver output)
		100ns			t <sub>sds</sub>	Data setup time
		100ns			t <sub>sdh</sub>	Data hold time

Pin	Signal	Min	Nom	Max	Condition	Note
5	SCLK	0.8*VIO		VIO	Logic '1'	Serial clock input
		0		0.22*VIO	Logic '0'	
				4.0MHz	Max frequency	
		250ns			t <sub>scyc</sub>	
		110ns			t <sub>shw</sub>	Clock high
		110ns			t <sub>slw</sub>	Clock low
6	VDDI (VIO)	1.72V	1.8V	1.88V		Logic voltage supply  Connected to VIO
7	VDD (VFLASH1)	2.72V	2.78V	2.86V		Voltage supply  Connected to VFLASH1
8	VOUT			9V		Booster output, C=1uF connected to GND

### DC connector

Pin	Signal	Min	Nom	Max	Condition	Note
2	VCHAR	7.0 V <sub>RMS</sub>	8.4 V <sub>RMS</sub>	9.2 V <sub>RMS</sub> 850 mA	Fast charger	Charger positive input
1	CHGND		0			Charger ground

### Headset connector

Pin	Signal	Min	Nom	Max	Condition	Note
5	XMICP			1V <sub>pp</sub>	G = 0dB	1kΩ to MIC2B
				100 mV <sub>pp</sub>	G = 20dB	
		2.0 V	2.1 V	2.25 V	DC	
3	XMICN			1V <sub>pp</sub>	G = 0 dB	1kΩ to GND
				100 mV <sub>pp</sub>	G = 20dB	
4	XEARN	0.75V	0.8V	0.85V	DC	
				1V <sub>pp</sub>	AC	
7	XEARP	0.75V	0.8V	0.85V	DC	
				1V <sub>pp</sub>	AC	
5	HookInt	0V		2.86V (VFLASH1)		Connected to UEM AD-converter
6	HeadInt	0V		2.86V (VANA)		Accessory detection

**SIM connector**

Pin	Name	Parameter	Min	Typ	Max	Unit	Notes
1	VSIM	1.8V SIM Card	1.6	1.8	1.9	V	Supply voltage
		3V SIM Card	2.8	3.0	3.2		
2	SIMRST	1.8V SIM Card	0.9xVSIM 0		VSIM 0.15xVSIM	V	SIM reset (output)
		3V SIM Card	0.9xVSIM 0		VSIM 0.15xVSIM		
3	SIMCLK	Frequency		3.25		MHz	SIM clock
		Trise/Tfall			50	ns	
		1.8V Voh 1.8V Vol	0.9xVSIM 0		VSIM	V	
		3 Voh 3 Vol	0.9xVSIM 0		VSIM		
4	DATA	1.8V Voh 1.8V Vol	0.9xVSIM 0		VSIM 0.15xVSIM	V	SIM data (output)
		3 Voh 3 Vol	0.9xVSIM 0		VSIM 0.15xVSIM		
		1.8V Vih 1.8V Vil	0.7xVSIM 0		VSIM 0.15xVSIM		SIM data (input) Trise/Tfall max 1us
		3V Vil 3V Vil	0.7xVSIM 0		VSIM 0.15xVSIM		
5	NC						
6	GND	GND		0		V	Ground

## Functional Description

### Modes of Operation

LA5 baseband engine has six different operating modes:

- No supply
- Backup
- Acting Dead
- Active
- Sleep
- Charging

#### No supply

In NO\_SUPPLY mode the phone has no supply voltage. This mode is due to disconnection of main battery and backup battery or low battery voltage level in both of the batteries.

Phone is exiting from NO\_SUPPLY mode when sufficient battery voltage level is detected. Battery voltage can rise either by connecting a new battery with  $V_{BAT} > V_{MSTR+}$  or by connecting charger and charging the battery above  $V_{MSTR+}$ .

#### Backup

In BACKUP mode the backup battery has sufficient charge but the main battery can be disconnected or empty ( $V_{BAT} < V_{MSTR}$  and  $V_{BACK} > V_{BU_{COFF}}$ ).

VRTC regulator is disabled in BACKUP mode. VRTC output is supplied without regulation from backup battery (VBACK). All the other regulators are disabled.

#### Acting Dead

If the phone is off when the charger is connected, the phone is powered on but enters a state called "Acting Dead". To the user the phone acts as if it was switched off. A battery charging alert is given and/or a battery charging indication on the display is shown to acknowledge the user that the battery is being charged.

#### Active

In the active mode the phone is in normal operation, scanning for channels, listening to a base station, transmitting and processing information. There are several sub-states in the active mode depending on if the phone is in burst reception, burst transmission, if DSP is working etc.

One of the sub-state of the active mode is FM radio on state. In that case UEM audio blocks and FM radio are powered on. FM radio circuitry is controlled by the MCU and 75kHz reference clock is generated in the UPP. VFLASH2 regulator is operating.

In active mode the RF regulators are controlled by SW writing into UEM's registers wanted settings: VR1A can be enabled or disabled. VR2 can be enabled or disabled and its output voltage can be programmed to be

2.78V or 3.3V. VR4 –VR7 can be enabled or disabled or forced into low quiescent current mode. VR3 is always enabled in active mode.

### Sleep mode

Sleep mode is entered when both MCU and DSP are in stand-by mode. Sleep is controlled by both processors. When SLEEPX low signal is detected UEM enters SLEEP mode. VCORE, VIO and VFLASH1 regulators are put into low quiescent current mode. All RF regulators are disabled in SLEEP. When SLEEPX=1 is detected UEM enters ACTIVE mode and all functions are activated.

The sleep mode is exited either by the expiration of a sleep clock counter in the UEM or by some external interrupt, generated by a charger connection, key press, headset connection etc.

In sleep mode VCTCXO is shut down and 32 kHz sleep clock oscillator is used as reference clock for the baseband.

### Charging

The battery voltage, temperature, size and current are measured by the UEM controlled by the charging software running in the UPP.

The charging control circuitry (CHACON) inside the UEM controls the charging current delivered from the charger to the battery. The battery voltage rise is limited by turning the UEM switch off when the battery voltage has reached 4.2 V. Charging current is monitored by measuring the voltage drop across a 220 mOhm resistor.

### Supply Voltage Regulation

Supply voltage regulation is controlled by UEM asic. There are six separate regulators used by baseband block.

### BB Regulators

Signal	Min	Nom	Max	Note
VANA	2.70V	2.78V	2.86V	I <sub>max</sub> = 80mA
VFLASH1	2.70V	2.78V	2.86V	I <sub>max</sub> = 70mA I <sub>Sleep</sub> = 1.5mA
VFLASH2	2.70V	2.78V	2.86V	I <sub>max</sub> = 40mA
VSIM	1.745V 2.91V	1.8V 3.0V	1.855V 3.09V	I <sub>max</sub> = 25mA I <sub>Sleep</sub> = 0.5mA
VIO	1.72V	1.8V	1.88V	I <sub>max</sub> = 150mA I <sub>Sleep</sub> = 0.5mA
VCORE	1.0V 1.235V 1.425V 1.710V	1.053V 1.3V 1.5V 1.8V	1.106V 1.365V 1.575V 1.890V	I <sub>max</sub> = 200mA I <sub>Sleep</sub> = 0.2mA Default value = 1.5V

## Battery

Li-ion battery pack BLB-2 is used in NHM-7.

Nominal discharge cut-off voltage	3.1V
Nominal battery voltage	3.6V
Nominal charging voltage	4.2V

### Pin numbering of battery pack

Signal name	Pin number	Function
VBAT	1	Positive battery terminal
BSI	2	Battery capacity measurement (fixed resistor inside the battery pack)
BTEMP	3	Battery temperature measurement (measured by ntc resistor inside pack)
GND	4	Negative/common battery terminal

### BLB-2 battery pack pin order

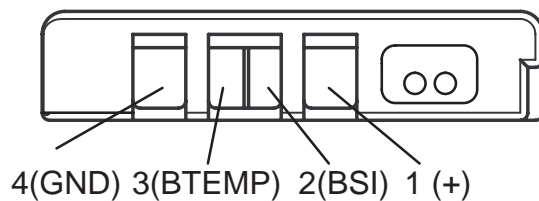

## Power Up and Reset

Power up and reset is controlled by the UEM ASIC. NHM-7 baseband can be powered up in following ways:

1. Press power button which means grounding the PWRONX pin of the UEM
2. Connect the charger to the charger input
3. Supply battery voltage to the battery pin
4. RTC Alarm, the RTC has been programmed to give an alarm

After receiving one of the above signals, the UEM counts a 20ms delay and then enters it's reset mode. The watchdog starts up, and if the battery voltage is greater than  $V_{\text{coff+}}$  a 200ms delay is started to allow references etc. to settle. After this delay elapses the VFLASH1 regulator is enabled. 500us later VR3, VANA, VIO and VCORE are enabled. Finally the PURX (Power Up Reset) line is held low for 20 ms. This reset, PURX, is fed to the baseband ASIC UPP, resets are generated for the MCU and

the DSP. During this reset phase the UEM forces the VCTCXO regulator on regardless of the status of the sleep control input signal to the UEM. The FLSRSTx from the ASIC is used to reset the flash during power up and to put the flash in power down during sleep. All baseband regulators are switched on at the UEM power on except SIM and VFLASH2 regulators which are controlled by the MCU. The UEM internal watchdogs are running during the UEM reset state, with the longest watchdog time selected. If the watchdog expires the UEM returns to power off state. The UEM watchdogs are internally acknowledged at the rising edge of the PURX signal in order to always give the same watchdog response time to the MCU.

## A/D Channels

The UEM contains the following A/D converter channels that are used for several measurement purpose. The general slow A/D converter is a 10 bit converter using the the UEM interface clock for the conversion. An interrupt will be given at the end of the measurement.

The UEM's 11-channel analog to digital converter is used to monitor charging functions, battery functions, voltage levels in external accessory detection inputs, user interface and RF functions.

When the conversion is started the converter input is selected. Then the signal processing block creates a data with MSB set to '1' and and others to '0'. In the D/A converter this data controls the switches which connect the input reference voltage (VrefADC) to the resistor network. The generated output voltage is compared with the input voltage under measurement and if the latter is greater, MSB remains '1' else it is set '0'. The following step is to test the next bit and the next...until LSB is reached. The result is then stored to ADCR register for UPP to read.

The monitored battery functions are battery voltage (VBATADC), battery type (BSI) and battery temperature (BTEMP) indication.

The battery type is recognized through a resistive voltage divider. In phone there is a 100kOhm pull up resistor in the BSI line and the battery has a pull down resistor in the same line. Depending on the battery type the pull down resistor value is changed. The battery temperature is measured equivalently except that the battery has a NTC pull down resistor in the BTEMP line.

KEYB1&2 inputs are used for keyboard scanning purposes. These inputs are also routed internally to the miscellaneous block. In NHM-7 KEYB1 input is used for flip detection.

The HEADINT and HOOKINT are external accessory detection inputs used for monitoring voltage levels in these inputs. They are routed internally from the miscellaneous block and they are connected to the converter through a 2/1 multiplexer.

The monitored RF functions are PATEMP and VCXOTEMP detection. PATEMP input is used to measure temperature of the RFIC, Hagar. VCXOTEMP is not used in NHM-7.

## FM Radio

FM radio circuitry is implemented using highly integrated radio IC, TEA5757. Only few external components like filters, discriminator and capacitors are needed.

TEA5757 is an integrated AM/FM stereo radio circuit including digital tuning and control functions. NHM-7 radio is implemented as superheterodyne FM mono receiver. FM stage of the TEA5757 incorporates a tuned RF stage, a double balanced mixer, one pin oscillator and is designed for distributed IF ceramic filters. IF frequency is 10.7 MHz.

Channel tuning and other controls are controlled by the MCU. Reference clock, 75kHz, is generated by the UPP CTSI block.

FM radio circuitry is controlled through serial bus interface by the MCU SW. TEA5757 informs MCU when channel is tuned by setting *FMTuneX* signal to logic '0'.

## Digital Interface

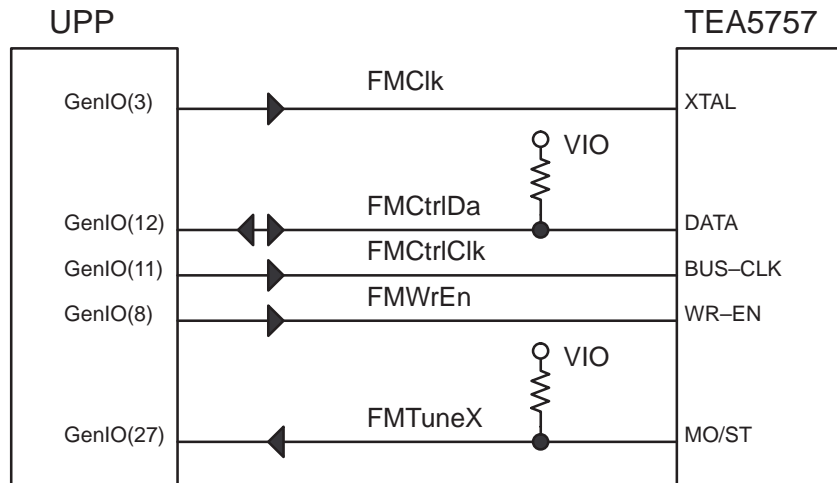

NOTE: *FMCtrlClk* needs to be set to logic '1' when data is not written or read. This is required for correct operation of the *FMTuneX* signal.

## FM radio audio & antenna connections

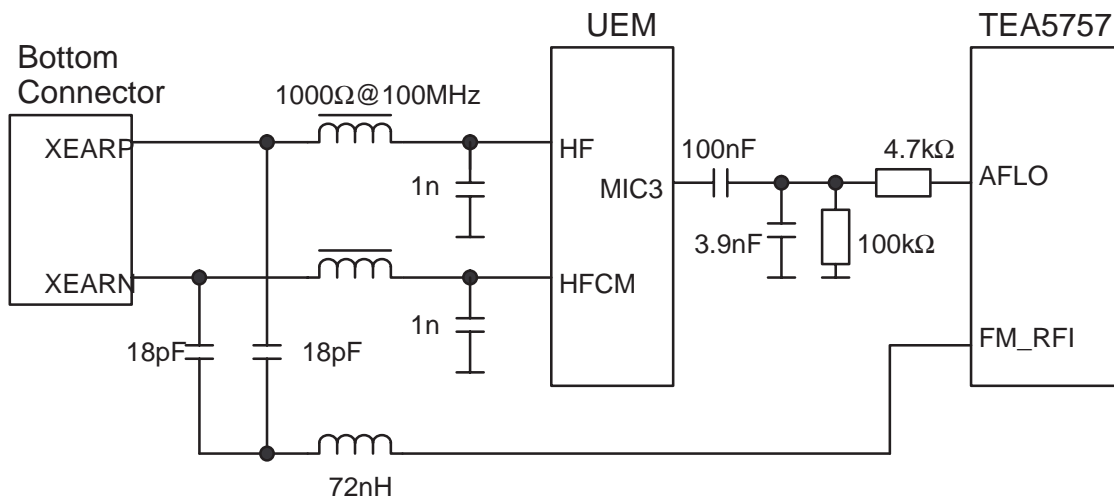



## IR Module

The IR interface, when using 2.7V transceiver, is designed into the UEM. The IR link supports speeds from 9600 bit/s to 1.152 MBit/s up to distance of 1m. Transmission over the IR is half-duplex.

The length of the transmitted IR pulse depends on the speed of the transmission. When 230.4 kbit/s or less is used as a transmission speed, pulse length is maximum 1.63us. If transmission speed is set to 1.152Mbit/s the pulse length is 154ns according to IrDA specification.

## Backup Battery

Backup battery is used in case when main battery is either removed or discharged. Backup battery is used for keeping real-time clock running for minimum of 30 minutes.

Rechargeable backup battery is connected between UEM VBACK and GND. In UEM backup battery charging high limit is set to 3.2V. The cut-off limit voltage ( $V_{BUCCoff-}$ ) for backup battery is 2.0V. Backup battery charging is controlled by MCU by writing into UEM register.

Polyacene SMD battery type is used. The nominal capacity of the battery is 0.2 mAh.

## SIM Interface

UEM contains the SIM interface logic level shifting. SIM interface can be programmed to support 3V and 1.8V SIMs. SIM supply voltage is selected by a register in the UEM. It is only allowed to change the SIM supply voltage when the SIM IF is powered down.

The SIM power up/down sequence is generated in the UEM. This means that the UEM generates the RST signal to the SIM. Also the SIMCardDet signal is connected to UEM. The card detection is taken from the BSI signal, which detects the removal of the battery. The monitoring of the BSI signal is done by a comparator inside UEM. The comparator offset is such that the comparator output do not alter state as long as the battery is connected. The threshold voltage is calculated from the battery size specifications.

The SIM interface is powered up when the SIMCardDet signal indicates "card in". This signal is derived from the BSI signal.

Parameter	Variable	Min	Typ	Max	Unit
SIMCARDet, BSI comparator Threshold	Vkey	1.94	2.1	2.26	V
SIMCARDet, BSI comparator Hysteresis (1)	Vsimhyst	50	75	100	mV

The whole SIM interface locates in two chip UPP and UEM.

The SIM interface in the UEM contains power up/down, port gating, card detect, data receiving, ATR-counter, registers and level shifting buffers logic. The SIM interface is the electrical interface between the Subscriber Identity Module Card (SIM Card) and mobile phone (via UEM device).

The data communication between the card and the phone is asynchronous half duplex. The clock supplied to the card is in GSM system 1.083 MHz or 3.25 MHz. The data baud rate is SIM card clock frequency divided by 372 (by default), 64, 32 or 16. The protocol type, that is supported, is T=0 (asynchronous half duplex character transmission as defined in ISO 7816-3).

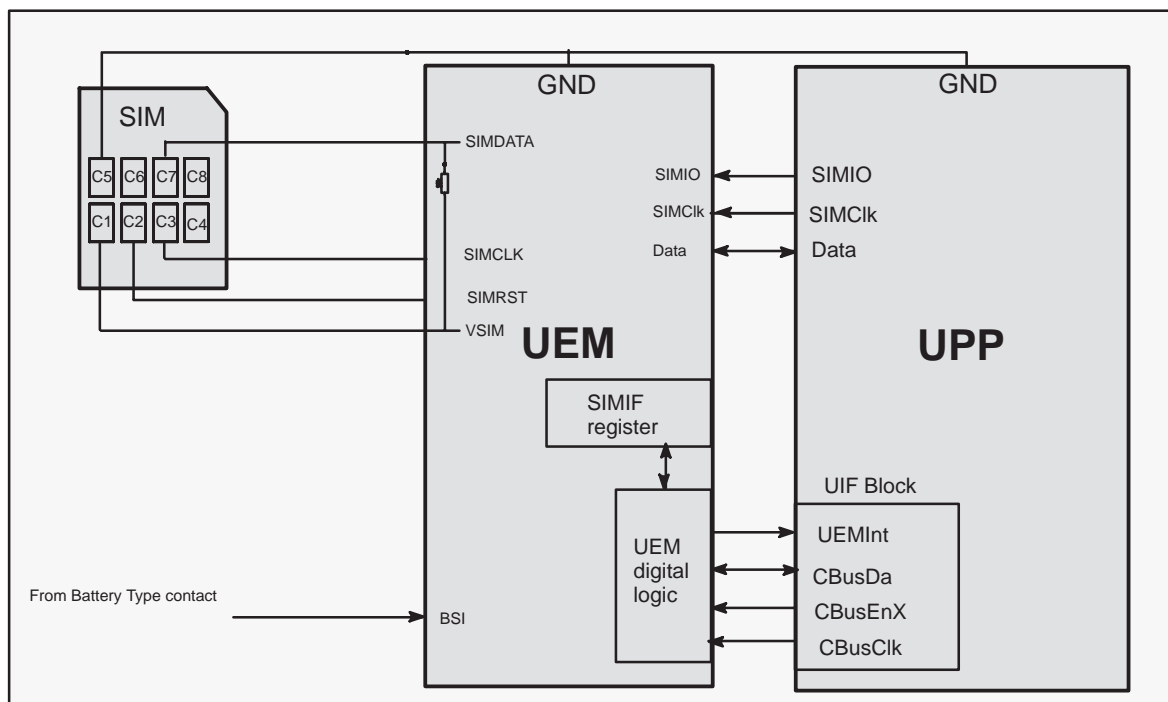

The internal clock frequency from UPP CTSI block is 13 MHz in GSM. Thus to achieve the minimum starting SIMCardClk rate of 3.25 MHz (as is required by the authentication procedure and the duty cycle requirement of between 40% and 60%) then the slowest possible clock supplied to the SIM has to be in the GSM system clock rate of 13/4 MHz.

## Buzzer

Buzzer is used to generate alerting tones and melodies to indicate incoming call. It is also used to generate keypress and warning tones for the user. Buzzer is controlled by PWM (Pulse Width Modulation) signal generated by the buzzer driver of the UEM. Target SPL is 100dB (A) at 5cm.

## Internal Microphone

The internal microphone capsule is mounted in the bottom connector. Microphone is omnidirectional. The internal microphone is connected to the UEM microphone input MIC1P/N. The microphone input is asymmetric and microphone bias is provided by the UEM MIC1B. The microphone input on the UEM is ESD protected. Spring contacts are used to connect the microphone contacts to the main PCB.

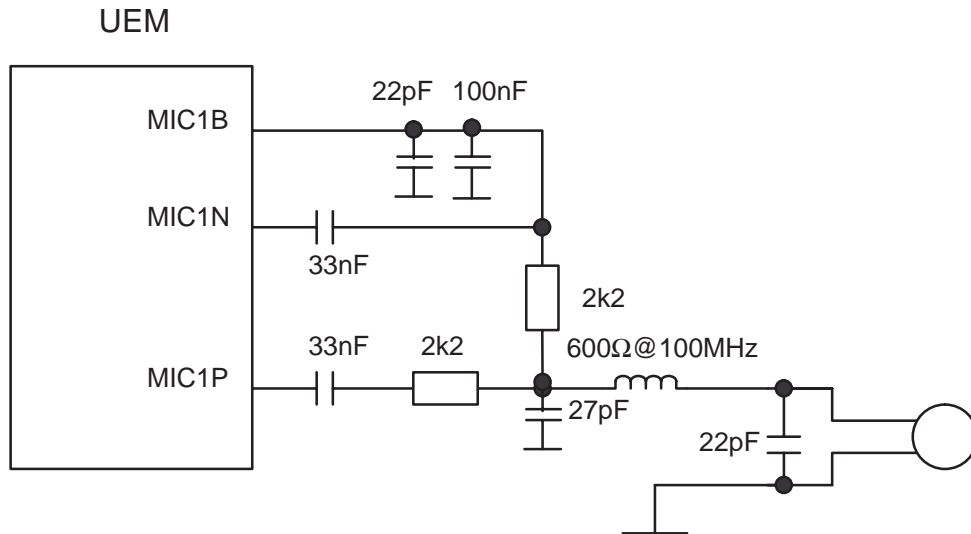

## UPP

UPP (Universal Phone Processor) is the digital ASIC of the baseband. UPP includes 8MBit internal RAM, ARM7 Thump 16/32-bit RISC MCU core, LEAD3 16-bit DSP core, ROM for MCU boot code and all digital control logic.

Main functions of the custom logic are:

1. Interface between system logic and MCU/DSP (BodyIf)
2. Clocking, timing, sleep and interrupt block (CTSI) for system timing control
3. MCU controlled general purpose USART, MBUS USART and general purpose IOs (PUP).
4. SIM card interface (SIMIf)
5. GSM coder (Coder)
6. GPRS support (GPRSCip)
7. Interfaces for keyboard, LCD and UEM (UIF)
8. Accessory interface for IrDA SIR, IrDA FIR and LPRF (Acclf)
9. SW programmable RF interface (MFI)
10. Programmable serial interface for Hagar RFIC (SCU)
11. Test interface (TestIf)

## Memory Block

For the MCU UPP includes ROM, 2 kbytes, that is used mainly for boot code of MCU. To speed up the MCU operation small 64 byte cache is also integrated as a part of the MCU memory interface. For program memory 8Mbit (512 x 16bit) PDRAM is integrated. RAM block can also be used as data memory and it is byte addressable. RAM is mainly for MCU purposes but also DSP has also access to it if needed.

MCU code is stored into external flash memory. Size of the flash is 64Mbit (4096 x 16bit) The NHM-7 baseband supports a burst mode flash with multiplexed address/data bus. Access to the flash memory is performed as 16-bit access. The flash has Read While Write capabilities which makes the emulation of EEPROM within the flash easy.

## RF Module

This RF module takes care of all RF functions of the engine. RF circuitry is located on one side (B-side) of the PCB.

EMC leakage is prevented by using a metal B-shield, which screens the whole RF side (included FM radio) of the engine. The conductive (silicon or metal) gasket is used between the PCB and the shield. The metal B-shield is separated to three blocks. The first one include the FM radio. The second block include the PA, antenna switch, LNAs and dual RX SAW. The last, but not least, block include the Hagar RF IC, VCO, VCTCXO, baluns and balanced filters. The blocks are divided on the basis that the attenuation between harmonics of the transmitter and the VCO signal (including Hagar IC) is a high (over 100dB). The VCO and TX outputs of the Hagar RF IC are located one another as far as possible. In order to guard against the radiated spurious inside blocks, the RF transmission lines are made with striplines after PA.

The baseband circuitry is located on the A-side of the board, which is shielded with a metallized frame and ground plane of the UI-board.

Maximum height inside on B-side is 1.8 mm. Heat generated by the circuitry will be conducted out via the PCB ground planes and metallic B-shield

## RF Frequency Plan

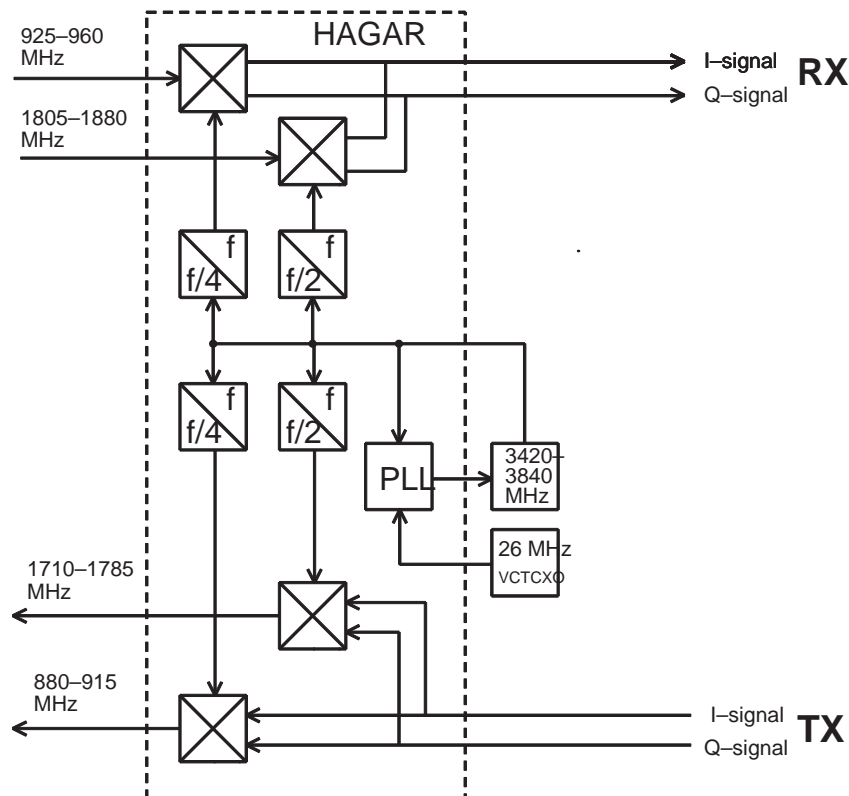

## DC characteristics

### Regulators

Transceiver has a multifunction power management IC on baseband section, which contains among other functions; 7 pcs of 2.78 V regulators and 4.8V up-switcher for charge pump.

All regulators can be controlled individually with 2.78 V logic directly or through control register. In GSM direct controls are used to get fast switching, because regulators are used to enable RF-functions.

Use of the regulators can be seen in the Power Distribution Diagram. VrefRF01 and VrefRF02 are used as the reference voltages for HAGAR RF-IC, VrefRF01 (1.35V) for bias reference and VrefRF02 (1.35V) for RX ADC's reference.

Regulators (except VR2 and VR7) are connected to HAGAR. Different modes were switched on by the aid of serial bus.

List of the needed supply voltages :

<b>Volt. source</b>	<b>Load</b>
VR1	PLL charge pump (4,8 V)
VR2	TX modulator
VR3	VCTCXO + buffer
VR4	HAGAR IC (LNAs+mixer+DTOS)
VR5	HAGAR IC (div+LO-buff+prescaler),
VR6	HAGAR (Vdd_bb)
VR7	VCO
VrefRF01	ref. voltage for HAGAR
VrefRF02	ref. voltage for HAGAR
Vbatt	PA

**Power Distribution Diagram**

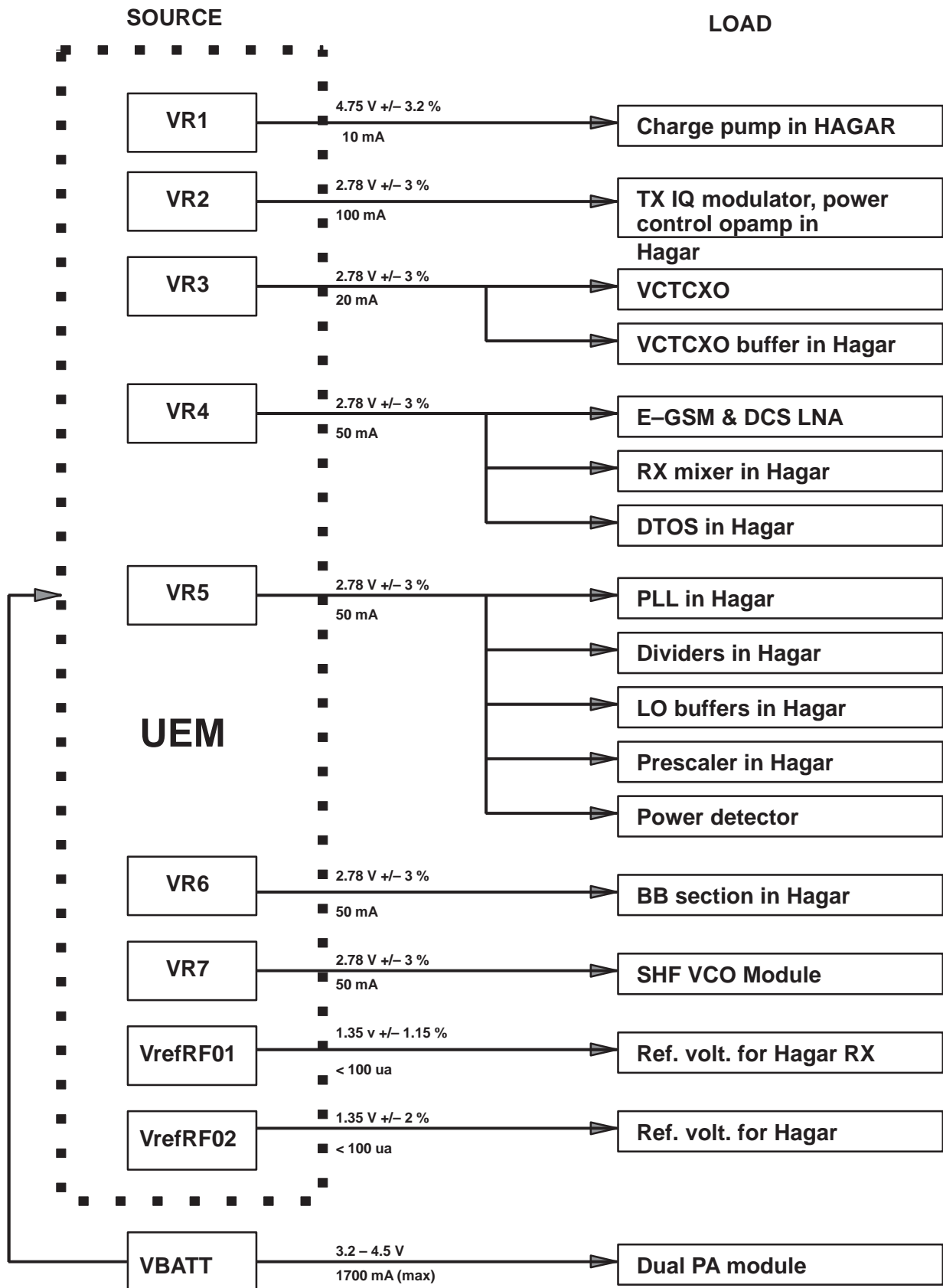

## RF characteristics

Item	Values (E-GSM / GSM1800)
Receive frequency range	925 ... 960 MHz / 1805...1880 MHz
Transmit frequency range	880 ... 915 MHz / 1710...1785 MHz
Duplex spacing	45 MHz / 95 MHz
Channel spacing	200 kHz
Number of RF channels	174 / 374
Power class	4 (2 W) / 1 (1 W)
Number of power levels	15 / 16

## Transmitter characteristics

Item	Values (E-GSM/GSM1800)
Type	Direct conversion, nonlinear, FDMA/TDMA
LO frequency range	3520...3660 MHz / 3420...3570 MHz
Output power	2 W / 1 W peak
Gain control range	min. 30 dB
Maximum phase error ( RMS/peak )	max 5 deg./20 deg. peak

## Receiver characteristics

Item	Values, E-GSM/GSM1800
Type	Direct conversion, Linear, FDMA/TDMA
LO frequencies	3700...3840 MHz / 3610...3760 MHz
Typical 3 dB bandwidth	+/- 91 kHz
Sensitivity	min. - 102 dBm (GSM1800 norm.cond. only)
Total typical receiver voltage gain ( from antenna to RX ADC )	86 dB
Receiver output level ( RF level -95 dBm )	230 mVpp, single-ended I/Q signals to RX ADCs
Typical AGC dynamic range	83 dB
Accurate AGC control range	60 dB
Typical AGC step in LNA	30 dB GSM1800    25 dB EGSM
Usable input dynamic range	-102 ... -10 dBm
RSSI dynamic range	-110 ... -48 dBm
Compensated gain variation in receiving band	+/- 1.0 dB



**RF Block Diagram**

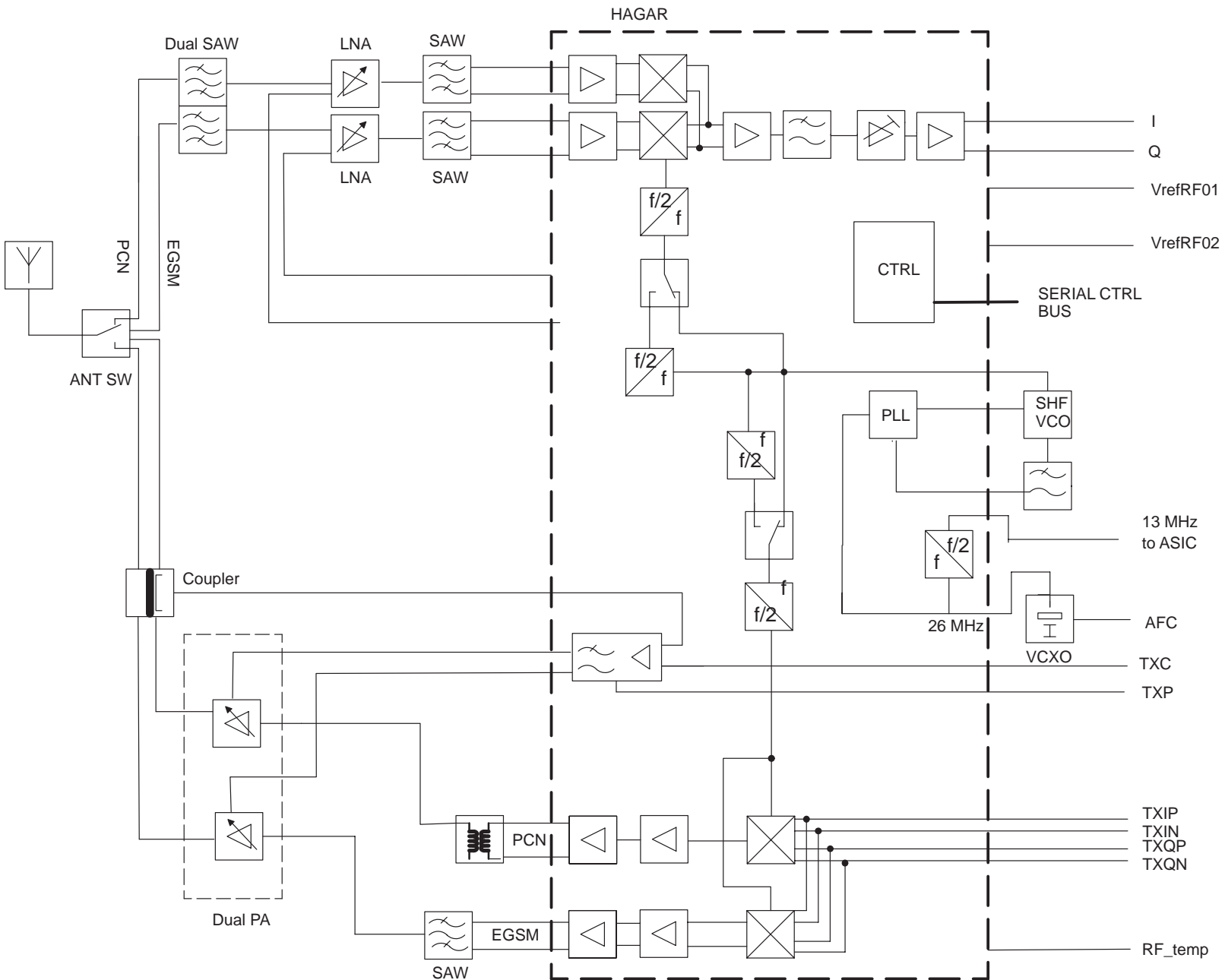

## Frequency synthesizers

VCO frequency is locked with PLL into stable frequency source, which is a VCTCXO-module ( voltage controlled temperature compensated crystal oscillator ). VCTCXO is running at 26 MHz. Temperature drifting is controlled with AFC ( automatic frequency control ) voltage. VCTCXO is locked into frequency of the base station. AFC is generated by baseband with a 11 bit conventional DAC. 13MHz VCTCXO can also be used if multislot operations is not needed. If more than 1(RX)+1(TX) slot is wanted settling times have to be less than 300us from channel to channel. This can be achieved when PLL loopbandwidth is ~35kHz. Noise coming from the loop and noise from dividers ( $20 \cdot \log N$ ) increases rms phase error over 3 degrees which is the maximum for synthesizer.

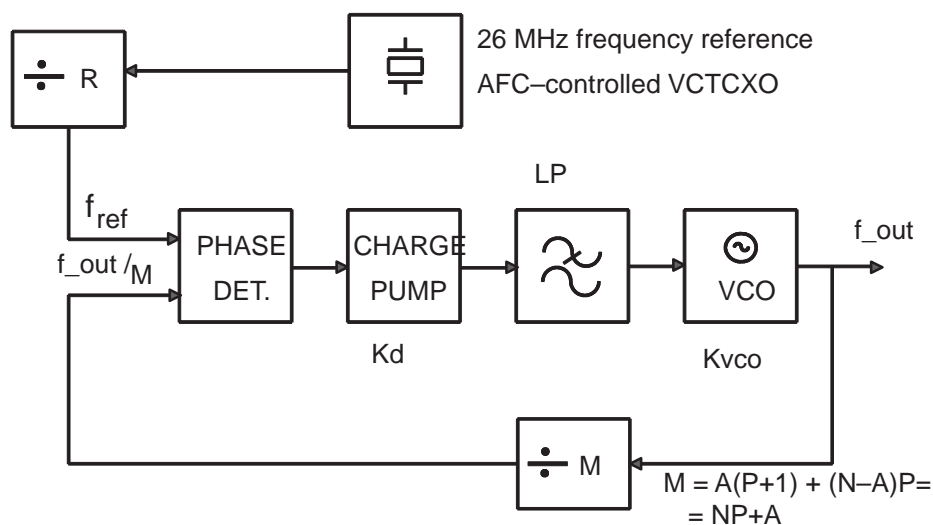

PLL is located in HAGAR RF-IC and is controlled via serial RFBUS. There is 64/65 ( $P/P+1$ ) prescaler, N- and A-divider, reference divider, phase detector and charge pump for the external loop filter. SHF local signal, generated by a VCO-module ( VCO = voltage controlled oscillator ), is fed thru 180deg balanced phase shifter to prescaler. Prescaler is a dual modulus divider. Output of the prescaler is fed to N- and A-divider, which produce the input to phase detector. Phase detector compares this signal to reference signal (400kHz), which is divided with reference divider from VCTCXO output. Output of the phase detector is connected into charge pump, which charges or discharges integrator capacitor in the loop filter depending on the phase of the measured frequency compared to reference frequency.

Loop filter filters out comparison pulses of phase detector and generates DC control voltage to VCO. Loop filter defines step response of the PLL ( settling time ) and effects to stability of the loop, that's why integrator capacitor has a resistor for phase compensation. Other filter components are for sideband rejection. Dividers are controlled via serial bus. RFBUS-Data is for data, RFBUSClk is serial clock for the bus and RFBUSEna1X is a latch enable, which stores new data into dividers.

LO-signal is generated by SHF VCO module. VCO has double frequency in GSM1800 and x 4 frequency in EGSM compared to actual RF channel

frequency. LO signal is divided by two or four in HAGAR (depending on system mode).

## Receiver

Receiver is a direct conversion, dual band linear receiver. Received RF-signal from the antenna is fed via RF-antenna switch module to 1st RX bandpass RF-SAW filters and MMIC LNAs (low noise amplifier). RF-antenna switch module contains upperband and lowerband operation. The LNA amplified signal is fed to 2nd RX bandpass RF-SAW filters. Both 2<sup>nd</sup> RX bandpass RF-SAW filters have un-bal/bal configuration to get the balanced (balanced) feed for Hagar.

Discrete LNAs have three gain levels. The first one is max. gain, the second one is about -30dB(GSM1800) and -25dB(EGSM900) below max. gain and the last one is off state. The gain selection control of LNAs comes from HAGAR IC.

RX bandpass RF-SAW filters define how good are the blocking characteristics against spurious signals outside passband and the protection against spurious responses.

Differential RX signal is amplified and mixed directly down to BB frequency in HAGAR. Local signal is generated with external VCO. VCO signal is divided by 2 (GSM1800) or by 4 (E-GSM900). PLL and dividers are in HAGAR-IC.

From the mixer output to ADC input RX signal is divided into I- and Q-signals. Accurate phasing is generated in LO dividers. After the mixer DTOS amplifiers convert the differential signals to single ended. DTOS has two gain stages. The first one has constant gain of 12dB and 85kHz cut off frequency. The gain of second stage is controlled with control signal g10. If g10 is high (1) the gain is 6dB and if g10 is low (0) the gain of the stage is -4dB.

The active channel filters in HAGAR provides selectivity for channels (-3dB @ +/-91 kHz typ.). Integrated base band filter is active-RC-filter with two off-chip capacitors. Large RC-time constants needed in the channel select filter of direct conversion receiver are produced with large off-chip capacitors because the impedance levels could not be increased due to the noise specifications. Baseband filter consists of two stages, DTOS and BIQUAD. DTOS is differential to single-ended converter having 8dB or 18dB gain. BIQUAD is modified Sallen-Key Biquad.

Integrated resistors and capacitors are tunable. These are controlled with a digital control word. The correct control words that compensate for the process variations of integrated resistors and capacitors and of tolerance of off chip capacitors are found with the calibration circuit.

Next stage in the receiver chain is AGC-amplifier, also integrated into HAGAR. AGC has digital gain control via serial mode bus. AGC-stage provides gain control range (40 dB, 10 dB steps) for the receiver and also the necessary DC compensation. Additional 10 dB AGC step is implemented in DTOS stages.

DC compensation is made during DCN1 and DCN2 operations (controlled via serial bus). DCN1 is carried out by charging the large external capacitors in AGC stages to a voltage which cause a zero dc-offset. DCN2 set the signal offset to constant value (VrefRF\_02 1.35 V). The VrefRF\_02 signal is used as a zero level to RX ADCs.

Single ended filtered I/Q-signal is then fed to ADCs in BB. Input level for ADC is 1.45 Vpp max.

Rf-temp port is intended to be used for compensation of RX SAW filters thermal behavior. This phenomena will have impact to RSSI reporting accuracy. The current information is -35ppm/C for center frequency drift for all bands. This temperature information is a voltage over two diodes and diodes are fed with constant current.

## Transmitter

Transmitter chain consists of two final frequency IQ-modulators for upper and lower band, a dual power amplifier and a power control loop.

I- and Q-signals are generated by baseband. After post filtering (RC-network) they go into IQ-modulator in HAGAR. LO-signal for modulator is generated by VCO and is divided by 2 or by 4 depending on system mode. There are separate outputs one for EGSM and one for GSM1800.

In EGSM branch there is a SAW filter before PA to attenuate unwanted signals and wideband noise from the Hagar IC.

The final amplification is realized with dual band power amplifier. It has two different power chains one for EGSM and one for GSM1800. PA is able to produce over 2 W (0 dBm input level) in EGSM band and over 1 W (0 dBm input level) in upperband band into 50 ohm output. Gain control range is over 45 dB to get desired power levels and power ramping up and down.

Harmonics generated by the nonlinear PA are filtered out with filtering inside the antenna switch -module.

Power control circuitry consists of discrete power detector (common for lower and upperband) and error amplifier in HAGAR. There is a directional coupler connected between PA output and antenna switch. It is a dual-band type and has input and outputs for both systems. Dir. coupler takes a sample from the forward going power with certain ratio. This signal is rectified in a schottky-diode and it produces a DC-signal after filtering.

The possibility to improve efficiency in low power levels has been specified in power amplifier module. The improved efficiency will take place on power level 7 and lower in EGSM. For this option there is control input line in PA module.

## AFC function

AFC is used to lock the transceivers clock to frequency of the base station. AFC-voltage is generated in BB with 11 bit DA-converter. There is a

RC-filter in AFC control line to reduce the noise from the converter. Settling time requirement for the RC-network comes from signalling, how often PSW ( pure sine wave ) slots occur. They are repeated after 10 frames. AFC tracks base station frequency continuously, so transceiver has a stable frequency, because changes in VCTCXO-output don't occur so fast ( temperature ).

Settling time requirement comes also from the start up-time allowed. When transceiver is in sleep mode and "wakes" up to receive mode , there is only about 5 ms for the AFC-voltage to settle. When the first burst comes in system clock has to be settled into +/- 0.1 ppm frequency accuracy. The VCTCXO-module requires also 5 ms to settle into final frequency. Amplitude rises into full swing in 1 ... 2 ms, but frequency settling time is higher so this oscillator must be powered up early enough.

## **DC-compensation**

DC compensation is made during DCN1 and DCN2 operations (controlled via serial bus). DCN1 is carried out by charging the large external capacitors in AGC stages to a voltage which cause a zero dc-offset. DCN2 set the signal offset to constant value (RXREF 1.35 V). The RXREF signal is used as a zero level to RX ADCs.

## UI Board LK5

NHM-7 consists of separate UI board, named as LK5, which includes contacts for the keypad domes and LEDs for keypad illumination. UI board is connected to main PWB through 16 pole board-to-board connector with springs. Signals of the connector are described in section External and Internal Signals and Connections.

5x4 matrix keyboard is used in NHM-7. Key pressing is detected by scanning procedure. Keypad signals are connected UPP keyboard interface.

When no key is pressed row inputs are high due to UPP internal pull-up resistors. The columns are written zero. When key is pressed one row is pulled down and an interrupt is generated to MCU. After receiving interrupt MCU starts scanning procedure. All columns are first written high and then one column at the time is written down. All other columns except one which was written down are set as inputs. Rows are read while column at the time is written down. If some row is down it indicates that key which is at the cross point of selected column and row was pressed. After detecting pressed key all register inside the UPP are reset and columns are written back to zero.

## LCD & Keypad Illumination

In NHM-7 white leds are used for LCD and keypad illumination. For LCD illumination four leds are used and for keypad six leds.

Current through leds is controlled by transistor circuitry. External transistor driver circuitry is used as constant current source in order to prevent any change in battery voltage be seen as changing led brightness. Battery voltage is changing for example during charging depending on a charger, battery type and age.

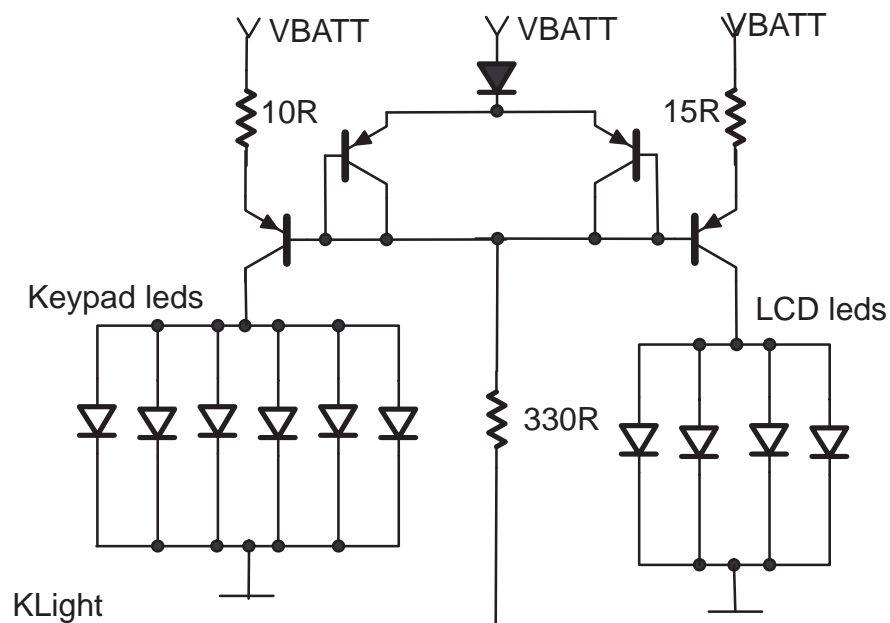

LEDs are controlled by the UEM PWM outputs. Both LEDs are controlled by *KLight* output of the UEM. Current flow through the LEDs is set by biasing the transistor and limiting the current by resistors. Current is set separately to keyboard and LCD leds.

### Internal Speaker

The internal earpiece is a dynamic earpiece with an impedance of 32 ohms. The earpiece is low impedance one since the sound pressure is to be generated using current and not voltage as the supply voltage is restricted to 2.7V. The earpiece is driven directly by the UEM and the earpiece driver in UEM is a bridge amplifier.

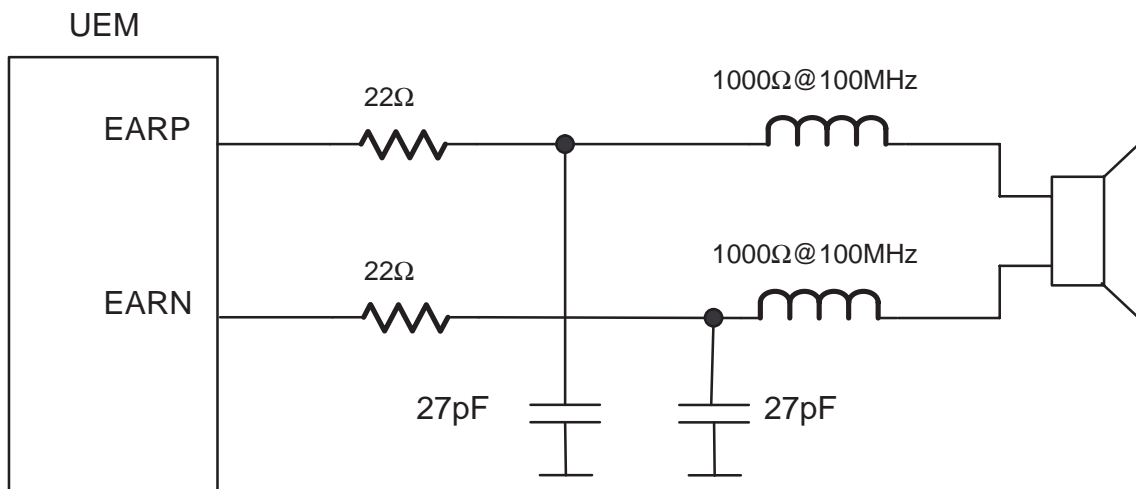

This page intentionally left blank.